

Injection/Extraction Studies In The Non-scaling FFAG For The Neutrino Factory

J. Pasternak^{†Δ}, M. Aslaninejad[†], J. Scott Berg[◇], D.J. Kelliher[#], S. Machida[#] and H. Witte[§]

† Imperial College London, Department of Physics, London, UK

ΔSTFC/RAL/ISIS, Chilton, Didcot, Oxon, UK

◇BNL, Upton, Long Island, New York, USA

#STFC/ASTeC/RAL, Chilton, Didcot, Oxon, UK

§JAI, University of Oxford, Oxford, OX1 3RH, UK

Abstract. The Neutrino Factory is under intensive study in the framework of the International Design Study for a future precision neutrino oscillation physics. According to current baseline the major part of muon acceleration is foreseen to take part in the non-scaling fixed field alternating gradient (NS-FFAG) ring. The NS-FFAG lattice design was recently modified to accommodate long straight sections necessary for the injection/extraction systems. The length of the long drift was optimized minimizing the necessary septum field, which according to present studies needs to be below 2 T. The injection/extraction schemes allowing to reuse the kickers for both signs of muons are presented. The design of the kicker system based on current technology is discussed. The preliminary design of septum magnet focused on minimization of the stray field leakage is studied.

Keywords: injection, extraction, muon acceleration, FFAG, the Neutrino Factory.

PACS: 41.75.Lx, 41.85.Ar, 41.85.Ne.

INTRODUCTION

The Neutrino Factory (NF) is a proposed accelerator neutrino source based on the decay of muons stored in the rings with long straight sections pointing towards far detectors, which aims for precision neutrino oscillation measurements in particular for the search of the leptonic CP violation. As the muon decay is one of the best known processes in particle physics, the neutrino beam generated by NF would be of a perfectly known flavour composition and spectrum. In order to confine the neutrino flux in the narrow cone, the muon beam needs to be accelerated to high energy. According to the current baseline under study in the framework of the International Design Study (IDS-NF) [1], the major part of acceleration would be performed in the non-scaling fixed field alternating gradient (NS-FFAG) ring, which would boost muons from 12.6 to the final 25 GeV. The unique properties of the NS-FFAG allows ultra fast acceleration with fixed frequency RF system maintaining high acceptance. The NS-FFAG would accelerate muons in about 12 turns, which offers more efficient use of RF than the re-circulating

linac (RLAs). The NS-FFAG, contrary to the RLA, requires the full aperture single turn beam injection and extraction. The results of the design of the realistic injection/extraction systems are the subject of this paper.

CHOICE OF THE BASELINE NS-FFAG LATTICE

The set of NS-FFAG lattices based on FDF triplet was designed with different lengths of the long straight section. The total cell length is always set to the multiple of half 201.25 MHz RF wavelengths to ensure the acceleration of both muon signs in opposite directions. The geometry of injection and extraction systems were studied in these lattices. A septum field of less than 2 T is chosen to minimize the effect of the septum stray field on the circulating beam. In order to estimate the clearance needed so that the extracted or injected beam avoids the magnet immediately following the septum, the dimensions of the superconducting combined function magnet (SCFM) in the J-PARC neutrino beam line is used. The width of the J-PARC SCFM from the inner radius of the

coils to the outer radius of the cold mass is 19.8 cm [2]. This distance is used, together with the size of the muon beam, in calculating the required septum bending angle. Taken together, these constraints impose a 5 m minimum long drift length on the lattice. The lattice with such drift length was chosen as a baseline and its parameters are summarized in Tab. 1.

TABLE 1. Parameters of the baseline NS-FFAG lattice.

Number of cells	64
Circumference	667 m
Lattice type	FDF triplet
Decay losses	6.7 %
Turns	11.6
RF voltage per turn	1.213 GV
Long drift length	5 m
Max F magnet field	- 4.3 T
Max D magnet field	6.1 T
F magnet gradient	18.0457 T/m
D magnet gradient	-13.5559 T/m

INJECTION/EXTRACTION GEOMETRY

Injection and extraction will occur at opposite ends of the ring. Each system will have reflection symmetry to accommodate both positively and negatively charged muons. There will be two septa in each system with kicker magnets between them. All the kickers in each system have the same strength. The septum and kicker magnets have length 4.4 m, i.e. there is 30 cm separation between these elements and the main magnets. Parameters for the kickers and septa for the injection/extraction systems are given in Tab. 2.

TABLE 2. Parameters of kickers and septa.

	Injection	Extraction
Kickers	2	4
Pattern	-0-	++00++
Kicker field	0.089 T	0.067 T
Septum field	0.92 T	1.76 T

In order to be feasible from an engineering perspective, the kicker magnet peak fields are constrained to be less than 0.1 T. The required separation between the kicked and circulating beams at the entrance of the septum is 2 cm. Two kicker magnets are required for injection. Due to the relatively high horizontal phase advance at this energy and the requirement of mirror symmetry, the kickers need to be separated by a single cell, resulting in an empty long drift at the centre of the injection system. At extraction four kickers are required, i.e. two pairs separated by two empty long drifts. Tracking results of the muon beam through the injection and extraction system are shown in Fig. 1 and 2 respectively. As can

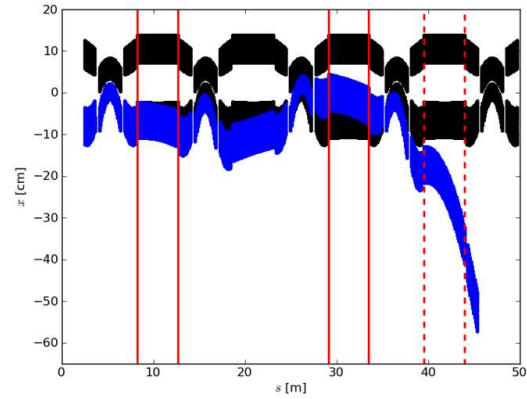

FIGURE 1. Beam tracking in the injection system. The blue injected beam travels from right to left. The circulating beams at injection and extraction energies are shown in black.

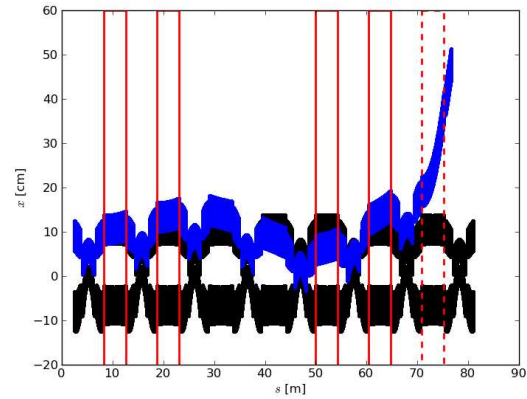

FIGURE 2. Beam tracking in the extraction system. The blue extracted beam travels from left to right. The circulating beams at injection and extraction energies are shown in black.

be seen in Fig 1, injection is into the inside of the ring whereas as shown in Fig. 2, the beam is extracted to the outside. The distribution of kickers over several cells means that a number of large aperture main magnets are required [3].

DESIGN OF KICKER SYSTEM

The kicker magnets of the traveling wave type are proposed both for injection and extraction. The kicker system consists of a power supply charging Pulse Forming Networks (PFNs), which are connected via fast switches of the thyatron type and coaxial cables to the kicker magnet and terminated via the matching resistor. The thyatron switch CX 1925X [4] and the coaxial cables RG192 connected in parallel could be used. A current of about 30 kA is necessary to produce

0.1 T top magnetic field in an aperture of about 0.3 m x 0.3 m. In order to keep the rise and fall times low, the kicker magnet needs to be subdivided into 4 or 5 smaller ones. The traveling wave type kicker magnet will comprise many cells with capacitance added in parallel in the form of metallic plates between them or external matching capacitors, used to match the impedance with the rest of the system, which is essential to minimize reflections. The voltage of 60 kV is assumed, which is compatible with the existing fast thyatron switches and sets the impedance value for the magnet and termination resistor to 1 Ohm. The thyatron CX 1925X is limited to 10 kA peak current, which dictates the use of three 3 Ohm PFNs connected in parallel for each subkicker. As the reference muon pulse consists of 3 muon bunch trains separated by 160 us, total of 9 PFNs for each subkicker are needed as it would require extremely demanding power supply to recharge the PFNs between the individual bunch trains. The total number of PFNs and switches per one kicker installed in the single drift is thus 36 (assuming that the kicker is subdivided into 4 subkickers). The power supplies of ~2.5 MW peak power are needed for every kicker. The schematic of the kicker system is shown in Fig. 3.

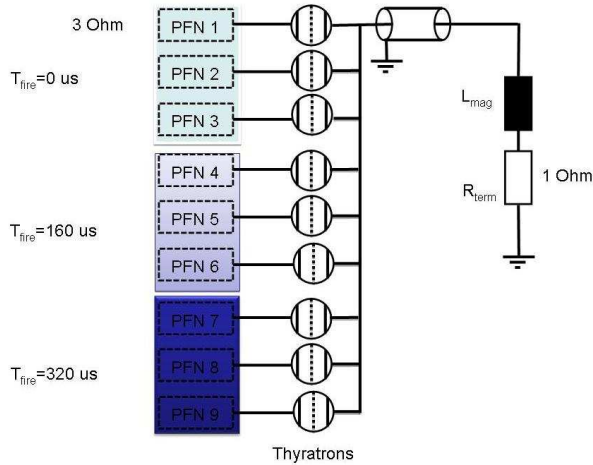

FIGURE 3. The design of the kicker system for 3 muon bunch trains.

SEPTUM STUDIES

It is proposed to use superconducting technology for the septa both for injection and extraction. In this way the high magnetic field can be easily obtained using very thin conductor (8 mm) with modest current density of 200 A/mm². The most challenging issue remains the shielding of the circulating beam area from the stray fields. In order to study the field leakage, the COMSOL 4.0 [6] simulations have been performed using various yoke geometries. The current design is based on the window frame magnet with the

yoke extending all around both extracted and circulating beam areas. The septum itself, which is 2 cm thick, is subdivided into the conductor part and the yoke part. As the yoke material, the soft magnetic cobalt-iron-alloy VACOFLUX50 [6] is used. In addition the chamfer was introduced on the side of the circulating beam in order to further limit the field leakage. The 2D design of the extraction septum is shown in Fig. 4. Based on the E-M simulations it is proposed to limit the septum field below 2 T, which dictates the length of the septum necessary to clear the beam with respect to main magnets.

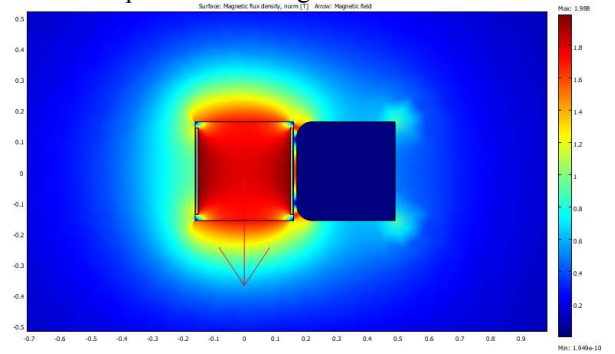

FIGURE 4. The 2D design of the SC septum.

SUMMARY

The NS-FFAG lattice was updated in order to allow for the realistic beam injection and extraction. The geometries for injection/extraction together with the kicker/septum parameters have been established. The design of the kicker system was proposed. The septum studies suggest to use the field below 2 T in order to limit the stray field leakage, which also sets the length of the long straight section in the NS-FFAG machine. The detailed design of the kicker and septum magnets will be addressed in the future studies.

ACKNOWLEDGMENTS

Authors would like to thank Dr L. Ducimetiere, his collaborators at CERN and Mr A. McFarland from RAL for many interesting and fruitful discussions.

REFERENCES

1. <http://www.ids-nf.org/>.
2. T. Ogitsu *et al.*, IEEE Trans. Appl. Supercond. 19,1081 (2009).
3. The Interim Design Report, The IDS-NF Collaboration, in preparation.
4. <http://www.e2v.com/>.
5. <http://www.comsol.com/>.
6. <http://www.vacuumschmelze.de/>.

